

PLYFOAM® II

COOLER AND FREEZER DOORS

- *White Metal Clad Finish*
- *Five-Year Warranty*



Cooler Door Shown
Right Hand Swing

COOLER DOOR SPECIFICATIONS:

Supply where indicated on plans Jamison Plyfoam® II Cooler Door.

Door panel to be constructed of #26 gauge white pre-painted stucco embossed steel pans front and back with reinforcement for hardware attachment.

Casing frame metal clad on all exposed surfaces with #26 gauge white pre-painted stucco embossed steel.

Door to be filled with 4" of Jamifoam non-CFC polyurethane insulation with an R value of 28 at 40°F.

Gasket at sides and head of door lip to be grease resistant synthetic skin with resilient sponge core, sill gasket to be sweep type.

Hardware to have protective coating against corrosion and to consist of self-rising hinges and safety release type fastener. (Permits door to be opened from inside even though padlocked on front.)

FREEZER DOOR SPECIFICATIONS:

Freezer door specifications to be same as cooler door except for these substitutions and additions:

Supply where indicated on plans Jamison Plyfoam® II Freezer Door.

Insulation R value is 32 at 40°F.

All metal cladding on warm side of door (front – unless otherwise specified) and frame to be applied with all seams and penetrating bolts sealed.

Provide Frostop heater cables in the sides and head of the frame and the bottom of the door at gasket contact areas. Heating cable to be assembled, ready for connection to 120 volt, 60 Hertz, single phase AC line.

SPECIAL NOTES:

1. When cold room temperature is below -20°F. or temperature difference is more than 90°F., contact factory.
2. If freezer door must be mounted in freezer room, please contact factory for recommendations.

OPTIONS: (SPECIFY which options are desired)

1. Metal cladding can be stainless steel, stucco aluminum, galvanized, or galvanized steel painted to meet specifications.
2. Kickplates – door and/or frame protected partial height (specify finish).
3. If doors to be used in meat processing plants subject to federal and state inspection, metal cladding to be applied per M.I.D. requirements.
4. Jambs/inside trim – see detail on back.
5. 6" of insulation for freezer door (R value of 48).
6. Door closer.
7. View Windows: 12" x 14" sealed glass unit.
 - a. Cooler Door – 2 layer, 1" thick.
 - b. Freezer Door – 3 layer, 1" thick with 120 V.A.C. heat film.
 - c. Other sizes available – contact factory.

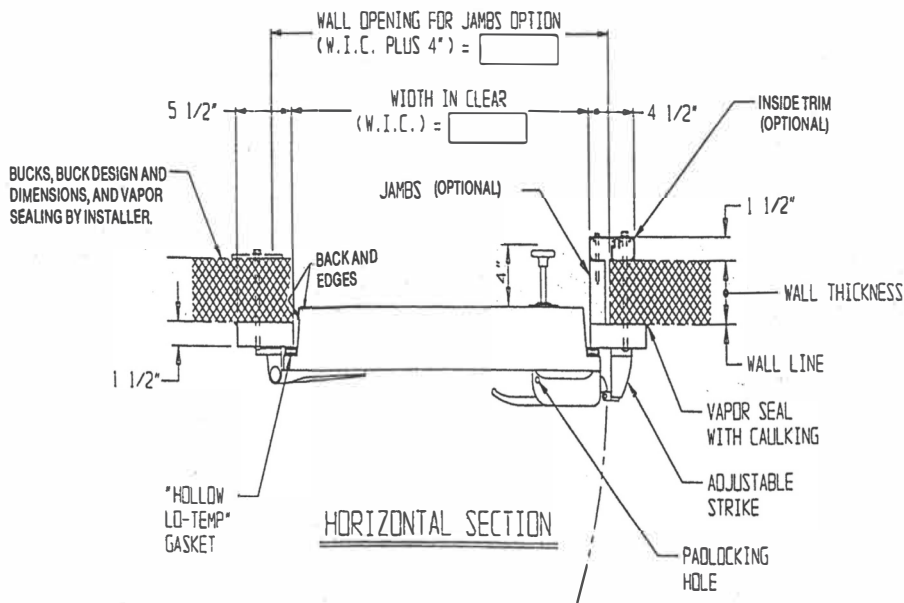
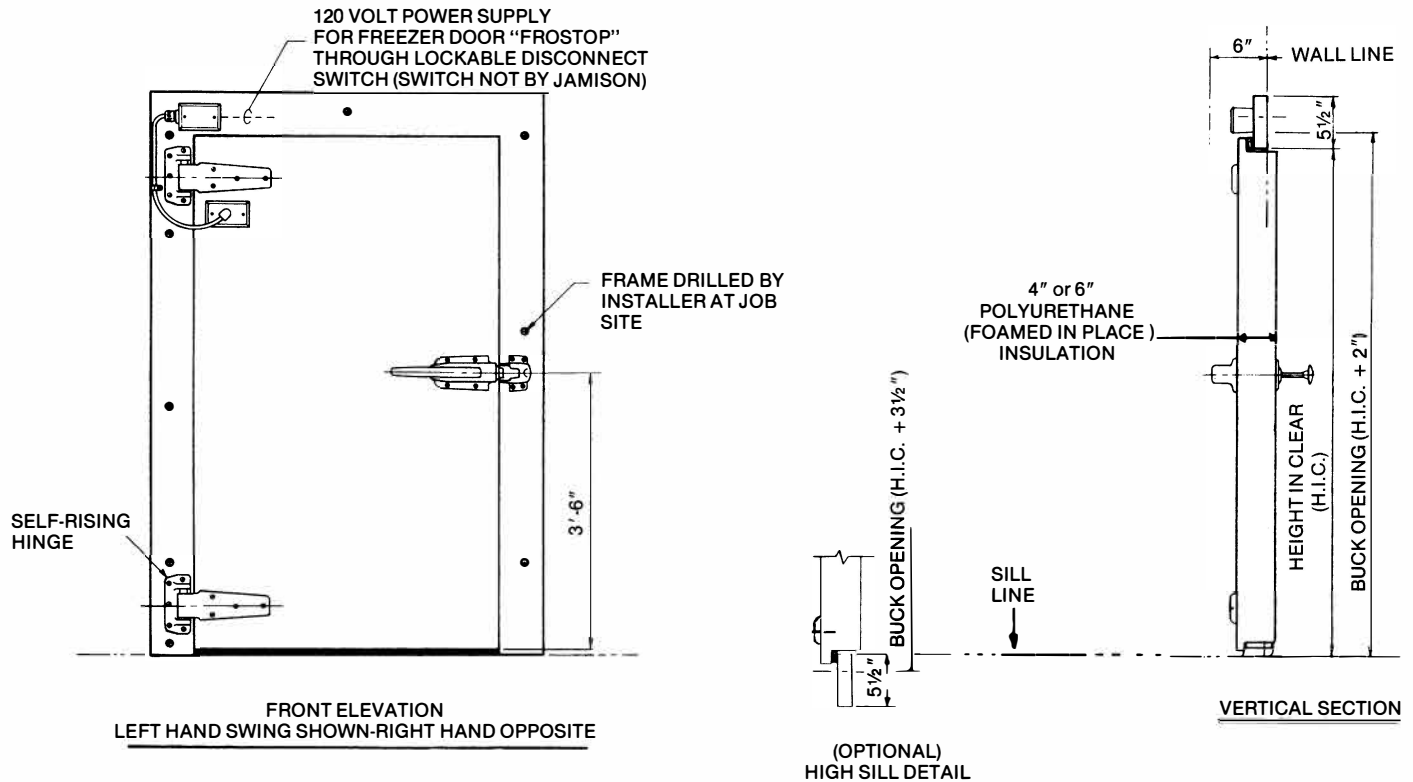

SIZES AVAILABLE

Standard sizes up to and including 5'0" width in clear x 8'0" height in clear.

INSTALLATION POINTS:

1. Bucks should be installed true, plumb and square and of sufficient size to accommodate door weight.
2. Wood bucks and back of door frame should be painted with a suitable preservative to protect against moisture penetration into wood.
3. Floor at door swing area should be smooth and level.
4. All bolts, lags and joints between buck and door frame should be vapor sealed with oil-suspended, nonhardening, waterproof caulking compound or similar material.

📍 Fray Pedro de Gante 85, Cimataro, Santiago de Querétaro, Querétaro, México CP 76030

📞 (442) 727-0441

✉️ contacto@klh.com.mx